

Sample Cylinders and Accessories

*Catalog 4160-SC
Revised, July 2002*



Sample Cylinders and Accessories

Sample Cylinders

Parker stainless steel and aluminum sample cylinders provide safe containment for storage and transportation of both liquids and gases. These cylinders are DOT rated to 1800 psig (124 bar) at 70 °F (21 °C). Applications include hydrocarbon sampling in refineries, gas sampling in chromatography, and condensate sampling in fossil fuel and nuclear power plants.

ANSI/ASME B1.20.1 internal pipe threads are machined into both ends of each cylinder to engage external pipe connections of Parker valves, rupture disc units, or fittings.

Stainless Steel Cylinders

Stainless steel sample cylinders are hot spun from seamless Type 316 tubing for integrity and corrosion resistance. The process provides a smooth internal flow transition through the neck to minimize pockets which can trap previous samples. Without the need for welding, the interior surface is free of any imperfections. As a result, less contamination will adhere to the interior surface when the cylinder is cleaned.

Aluminum Cylinders

Aluminum cylinders are fabricated from 6061 aluminum using an impact extrusion process and are subsequently heat treated to T6 temper. They have smooth interior surfaces with no welds, seams, or folds. They are approximately one-half the weight of an equivalent size stainless steel sample cylinder.

Features

Stainless Steel Cylinders

- Pressure and temperature rating:
1800 psig (124 bar);
-58 °F to 450 °F (-50 °C to 232 °C)
- DOT-3E 1800:
75, 150, 300, and 500cc with 1/4" NPT threads
- DOT-3A 1800:
1000 and 2250cc with 1/4" NPT threads
- DOT-3A 1800:
3785cc (1 gallon) with 1/2" NPT threads

Aluminum Cylinders

- Pressure and temperature rating:
1800 psig (124 bar);
0 °F to 130 °F (-18 °C to 54 °C)
- DOT-E 7737 1800:
150, 300, and 500cc with
1/4" NPT threads



4F-SC75D-SS



4F-SC150D-A



4F-SC150D-SS



4F-SC300D-A



4F-SC300D-SS



4F-SC500D-SS



4F-SC500D-A

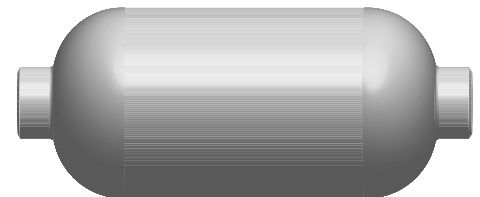

4F-SC1000D-SS

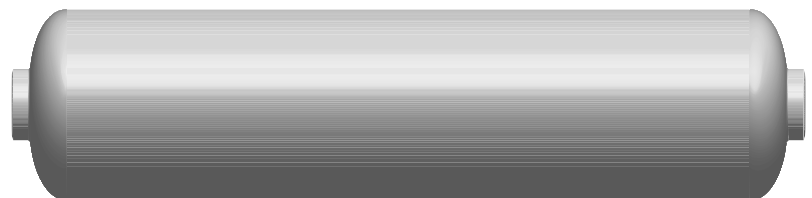

4F-SC2250D-SS-WC

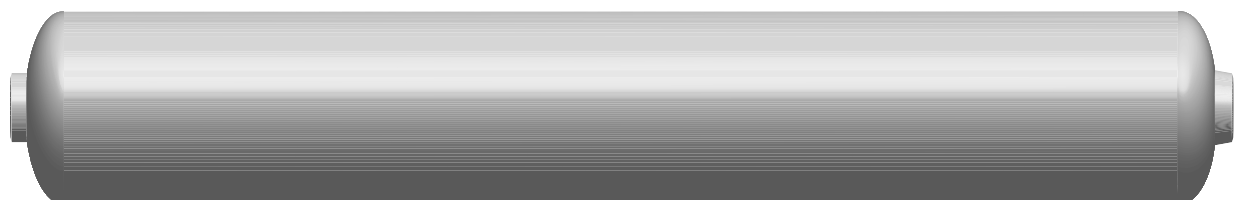

8F-SC1GD-SS-WC

Sample Cylinders and Accessories

Cylinder Design, Production and Testing

The design, manufacture and testing of steel sample cylinders is regulated by the US government in 49 CFR, Paragraphs 178.36 *Specification 3A; seamless steel cylinders* and 178.42 *Specification 3E; seamless steel cylinders*. Aluminum sample cylinders are governed by the same paragraphs, supplemented by Exemption DOT-E 7737. Specification 3A deals with cylinders not over 1,000 pounds (455 kg) water capacity and Specification 3E is for cylinders having an outside diameter no greater than 2 inches (51 mm), with a length less than 2 feet (61 cm). Service pressure is limited to 1,800 psi (124 bar) for Parker Sample Cylinders.

The above regulations control all aspects of the design and production of sample cylinders. Material physical properties and chemical characteristics are controlled. Each cylinder must be hydrostatically tested between 3,000 and 4,500 psi (207 and 310 bar). In addition, one cylinder out of each lot of 500 or less must be subjected to a burst test and result in a safety factor on burst pressure of 3.3 minimum.

All cylinder tests must be inspected and verified by an independent inspection agency, and all test reports must be maintained for fifteen years. Each cylinder must also be marked and packaged in accordance with 49 CFR.

Note: DOT-3A 1800 cylinders must also be re-tested every five years at 3,000 psig (207 bar).

DOT Approved Materials for use in Aluminum Sample Cylinders

Air, Compressed	Ethane	Methane
Ammonia, anhydrous	Ethylene	Methylamine, anhydrous
Argon	Ethylene oxide	Methyl butene
Boron trichloride	Flammable liquid, n.o.s.	Monoethylamine
Butadiene, inhibited	(Dimethylpropane)	Neon
Butane	Refrigerant gas (Freon)	Nitrogen
Carbon Dioxide, liquefied	Helium	Nitrous oxide*
Compressed gas, n.o.s. (Bromotrifluoroethylene)	Hydrocarbon gas, non-liquefied (Coal gas)	Pentane
Compressed gas, n.o.s. (Deuterium)	Hydrogen	Propane
Compressed gas, n.o.s. (Difluoroethylene)	Hydrogen sulphide	Sulphur dioxide
Compressed gas, n.o.s. (Krypton)	Isobutane	Sulphur hexafluoride
Compressed gas, n.o.s. (Ozone)	Isobutylene	Trimethylamine, anhydrous
Cyclopropane	Liquefied petroleum gas (Butene)	Vinyl chloride
Dimethylamine, anhydrous	Liquefied petroleum gas (Cyclobutane)	Vinyl fluoride, inhibited
Dimethyl ether	Liquefied petroleum gas (Propylene)	Xenon

***Note:** If cleaned per Federal Specification RR-C-90lb.
n.o.s. = not otherwise specified

Caution: Aluminum sample cylinders exposed to a fire or heated to temperature in excess of 350 °F (177 °C) should be condemned and/or hydrostatically tested prior to filling. In addition, aluminum sample cylinders should not be cleaned or evacuated at temperatures above 350 °F (177 °C).

How to Order / Dimensions

Material	DOT	Minimum Internal Volume (cc)	Part Number		Dimensions (ref.)				Approximate Weight	
					Length		Outside Diameter			
			Single-End*	Double-End	inch	mm	inch	mm	lb	kg
316 Stainless Steel	DOT-3E 1800	75	4F-SC75S-SS	4F-SC75D-SS	4.88	124	1.50	38	0.60	0.27
		150	4F-SC150S-SS	4F-SC150D-SS	8.13	206	1.50	38	1.00	0.45
		300	4F-SC300S-SS	4F-SC300D-SS	9.25	235	2.00	51	1.80	0.82
	DOT-3A 1800	500	4F-SC500S-SS	4F-SC500D-SS	13.88	352	2.00	51	2.50	1.14
		1000	4F-SC1000S-SS	4F-SC1000D-SS	9.50	241	4.00	102	7.50	3.41
		2250	4F-SC2250S-SS-WC	4F-SC2250D-SS-WC	16.5**	419**	4.00	102	12.00	5.45
		3785	8F-SC1GS-SS-WC	8F-SC1GD-SS-WC	25.5**	648**	4.00	102	17.80	8.09
6061-T6 Aluminum	DOT-E 7737 1800	150	4F-SC150S-A	4F-SC150D-A	5.75	146	1.99	51	0.50	0.23
		300	4F-SC300S-A	4F-SC300D-A	9.84	250	1.99	51	0.78	0.35
		500	4F-SC500S-A	4F-SC500D-A	14.91	379	1.99	51	1.23	0.56

*A stainless steel pipe plug is supplied for use in one end of the cylinder when a single-ended cylinder is ordered.

**Includes threaded neck rings and caps. Add 6 1/4" (159 mm) to each end to include cap lengths.

Sample Cylinders and Accessories

V4LC Series Miniature Needle Valves

Features

- Stainless steel construction
- Tapered bore PTFE packing
- Optional R stem (All metal, blunt tip) or K stem (PCTFE stem tip)
- Knurled aluminum handle
- Optional stem packings

Specifications

- Pressure rating: 5000 psig CWP (345 bar)
- Temperature ratings:
 - With PTFE packings:
 - R stem: -65 °F to 450 °F (-54 °C to 232 °C)
 - K stem: -65 °F to 350 °F (-54 °C to 177 °C)
 - With Buna-N rubber packing: -30 °F to 250 °F (-34 °C to 121 °C)
 - With Fluorocarbon rubber packings: -15 °F to 400 °F (-26 °C to 204 °C)
 - With Ethylene propylene rubber packing: -70 °F to 275 °F (-21 °C to 135 °C)
 - With Neoprene rubber packing: -65 °F to 250 °F (-54 °C to 121 °C)
- Ports: ANSI/ASME B1.20.1; 1/4" external pipe threads
- Orifice: 0.176" (4.5mm)

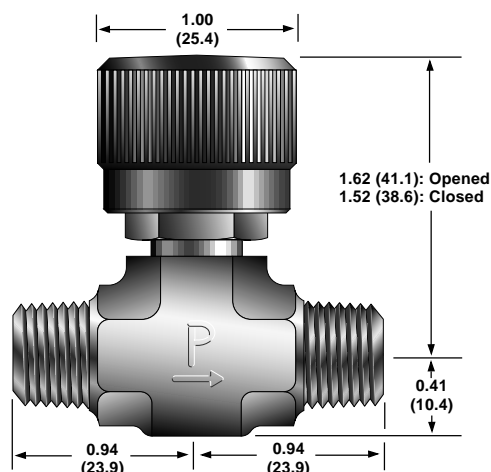

Model Shown: **4M-V4LCK-SS**
 () Denotes dimensions in millimeters

How to Order*

With K stem: 4M-V4LCK-SS
 With R stem: 4M-V4LCR-SS

***Note:** To obtain optional elastomeric stem packing, insert one of the following designators prior to -SS:
BN – Buna-N rubber, **V** – Fluorocarbon rubber,
EPR – Ethylene propylene rubber, **NE** – Neoprene rubber.
Example: 4M-V4LCK-BN-SS

Materials of Construction

Item #	Part Description	Material
1	Body	ASTM A 182 Type F316
2	Packing Nut	ASTM A 479 Type 316
3	Handle	ASTM B 211 Alloy A92024
4	Lower Packing Washer	316 Stainless Steel
5	Handle Set Screw	316 Stainless Steel
6	Packing	PTFE
7	R Stem	ASTM A 276 Type 316
7	K Stem	ASTM A 276 Type 316 with PCTFE
8	Upper Packing Washer	Commercial Brass

Lubrication: Graphite filled hydrocarbon

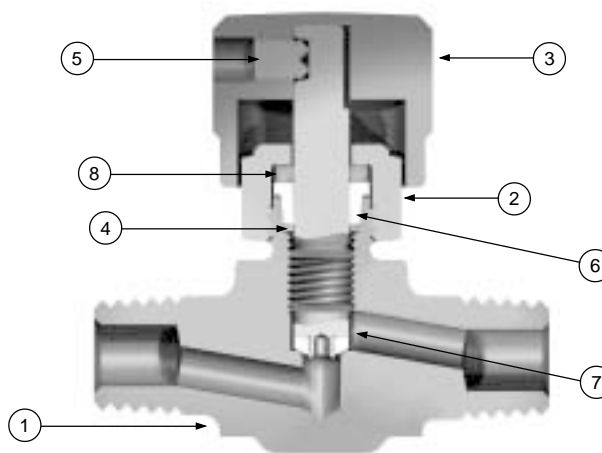

Rupture Disc Units

Features

Parker Rupture Disc Units are designed for direct engagement to aluminum and stainless steel sample cylinders for protection against overpressure. The unit features a pre-bulged 316 stainless steel rupture disc. The pre-bulged disc design minimizes fragmentation upon burst and provide close tolerance of the actual burst pressure.

Specifications

- Pressure Rating:*
1800 psig at 70 °F (124 bar at 21 °C)
- Temperature Rating:
With standard PTFE gasket:
-65 °F to 150 °F (-54 °C to 66 °C)
With optional metal gasket:
-65 °F to 400 °F (-54 °C to 204 °C)

***Note:** Contact your Parker Distributor for availability of optional rupture disc pressures from 160 psig to 5000 psig (11 bar to 345 bar).

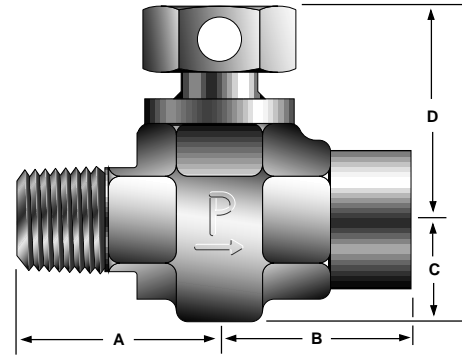

Model Shown: 4M4F-RV6L-18-SS

Materials of Construction

Part Description	Material
Body	ASTM A 182 Type F316
Plug	ASTM A 479 Type 316
Rupture Disc	AISI Type 316*
Gasket	PTFE or 316 Stainless Steel with PTFE coating

***Note:** Rupture disc material will be aluminum for pressures below 1250 psig (86 bar).

How to Order / Dimensions

Part Number	Inlet	Outlet	Dimensions							
			A		B		C		D	
			inch	mm	inch	mm	inch	mm	inch	mm
4M4F-RV6L-18-SS	1/4" MNPT	1/4" FNPT	1.00	25.4	1.00	25.4	0.53	13.5	1.15	29.2
8M8F-RV6L-18-SS	1/2" MNPT	1/2" MNPT	1.38	35.1	1.38	35.1	0.61	15.5	1.31	33.3

Options

- Metal gasket – Add the suffix **-HT** to the end of the part number. Example: 4M4F-RV6L-18-SS-**HT**
- Dip tubes – See page 7

Burst Pressure vs. Temperature (1800 psig Rupture Disc)

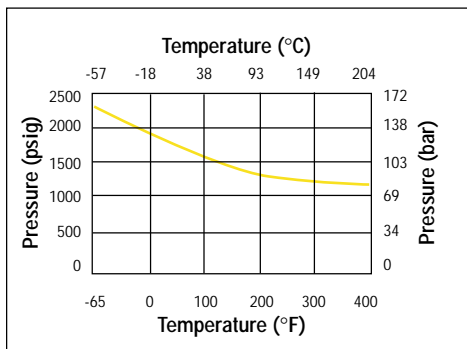

Precautions

1. Ensure the minimum burst pressure rating of the Rupture Disc Unit is approximately 40% higher than the cylinder service (filling) pressure.
2. Do not use Rupture Disc Units in a location where the release of the contents may cause death, personal injury and property damage. Rupture Disc Units are a CGA Type CG-1 pressure relief device and are designed to release the entire contents of the cylinder to atmosphere.
3. Follow the minimum recommended practices for maintenance and inspection of pressure relief devices in CGA Pamphlet S-1.1. Inspect the rupture disc frequently. Preferably, replace the disc yearly. Temperature and pressure cycling, and corrosive media can affect the disc's burst pressure.
4. For additional information on Parker Rupture Disc Units, refer to any of the Maintenance and Installation Instructions for Rupture Discs and Combination Needle/ Rupture Discs (INI-207, INI-219, MI-107, and MI-117).

Sample Cylinders and Accessories

RV6C Series Combination Rupture Disc / Needle Valves

Features

- Combines the V4LC Series valve and the RV Series rupture disc unit into a small package
- Stainless steel construction
- Tapered bore PTFE packing
- K stem (PCTFE stem tip)
- Knurled aluminum handle
- Inline and angle patterns
- Optional stem packings

Specifications

- Pressure rating:
 - Valve – 5000 psig CWP (345 bar)
 - Rupture Disc – 1800 psig (124 bar)
- Temperature Rating:
 - With standard PTFE gasket:
 - 65 °F to 150 °F (-54 °C to 66 °C)
 - With optional metal gasket and proper seal:
 - 65 °F to 400 °F (-54 °C to 204 °C)
 - With PTFE packing:
 - 65 °F to 350 °F (-54 °C to 177 °C)
 - With Buna-N rubber packing:
 - 30 °F to 250 °F (-34 °C to 121 °C)
 - With Fluorocarbon rubber packing:
 - 15 °F to 400 °F (-26 °C to 204 °C)
 - With Ethylene propylene rubber packing:
 - 70 °F to 275 °F (-21 °C to 135 °C)
 - With Neoprene rubber packing:
 - 65 °F to 250 °F (-54 °C to 121 °C)
- Ports: ANSI/ASME B1.20.1;
 - Inlet – 1/4" external pipe threads
 - Outlet – 1/4" internal pipe threads
- Orifice: 0.176" (4.5mm)

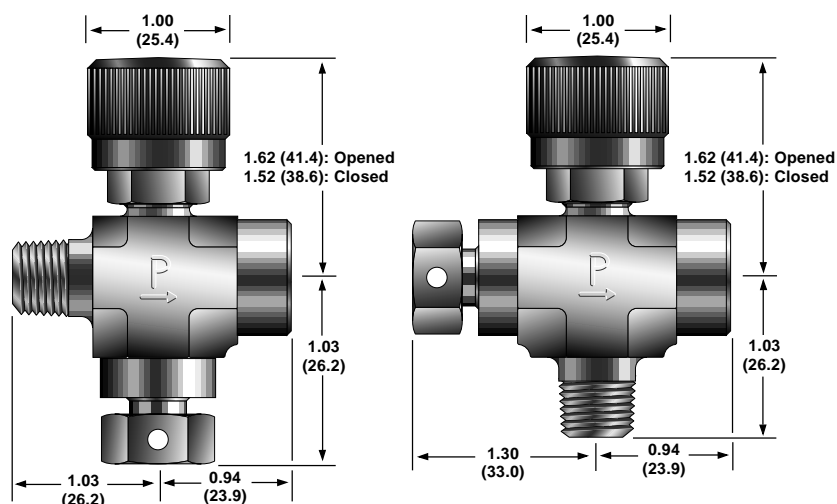

Model Shown: 4M4F-RV6LCK-18-SS

Model Shown: 4M4F-RV6ACK-18-SS

() Denotes dimensions in millimeters

How to Order*

Inline pattern: 4M4F-RV6LCK-18-SS

Angle pattern: 4M4F-RV6ACK-18-SS

*Note:

1. To obtain optional elastomeric stem packing, insert one of the following designators prior to –SS:
 - BN** – Buna-N rubber, **V** – Fluorocarbon rubber, **EPR** – Ethylene propylene rubber, **NE** – Neoprene rubber.
 - Example:** 4M4F-RV6LCK-18-V-SS
2. To obtain the optional high temperature gasket, add the suffix – HT to the end of the part number.
 - Example:** 4M4F-RV6LCK-18-V-SS-HT

Materials of Construction

Item #	Part Description	Material
1	Stem	ASTM A 276 Type 316 with PCTFE
2	Packing Nut	ASTM A 479 Type 316
3	Body	ASTM A 182 Type F316
4	Plug	ASTM A 479 Type 316
5	Handle Set Screw	316 Stainless Steel
6	Handle	ASTM B 211 Alloy A92024
7	Packing	PTFE
8	Lower Packing Washer	316 Stainless steel
9	Gasket	PTFE or 316 Stainless Steel with PTFE coating
10	Rupture Disc	AISI Type 316
11	Upper Packing Washer	Commercial Brass

Lubrication: Graphite filled hydrocarbon

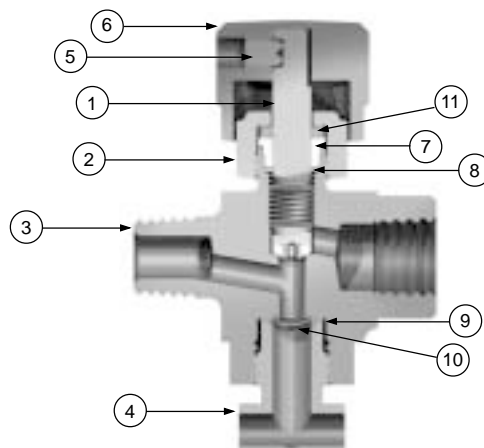

Dip (Outage) Tube Valves and Fittings

Parker Sample Cylinder Valves and Rupture Disc Units may be fitted with customer specified dip tubes to prevent overfilling of cylinders by providing a vapor space in sample cylinders containing liquefied gases. Parker Dip Tube Fittings permit the assembly of any valve with a dip tube.

How to Order Dip Tubes with Sample Cylinder Valves and Rupture Disc Units

A 316 stainless steel dip tube will be supplied press fit to the Male NPT port of products when specified by adding the **dip tube length** to the end of the part number. The length is measured from the end of the forging.

Example 1: 4M4F-RV6L-18-SS-4. Describes a Rupture Disc Unit with a four inch (102mm) long dip tube.

Example 2: 4M4F-RV6LCK-18-SS-2. Describes a Combination Rupture Disc / Needle Valve with a two inch (51 mm) long dip tube.

How to Order Dip Tube Fittings

A 316 stainless steel dip tube will be supplied press fit to the Male NPT port of Male x Female Pipe Adapters. They are available with 1/4" or 1/2" NPT threads. Specify the custom DT6L fitting by adding the **dip tube length** to the end of the part number. The length is measured from the end of the forging.

Example 1: 4M4F-DT6L-SS-3. Describes a 1/4" MNPT x 1/4" FNPT Fitting with a 3 inch (76 mm) long dip tube.

Example 2: 8M8F-DT6L-SS-2. Describes a 1/2" MNPT x 1/2" FNPT Fitting with a 2 inch (51 mm) long dip tube.

Note: For further information on Dip (Outage) Tubes, refer to Parker Engineering Performance Report EPR4160.2

Other Valves for use with Sample Cylinders

- V Series Needle Valves (Catalog 4110-V)
- SN Series Needle Valves (Catalog 4110-SN)
- NP Series Needle Valves (Catalog 4110-NP)
- U Series Needle Valves (Catalog 4110-U)

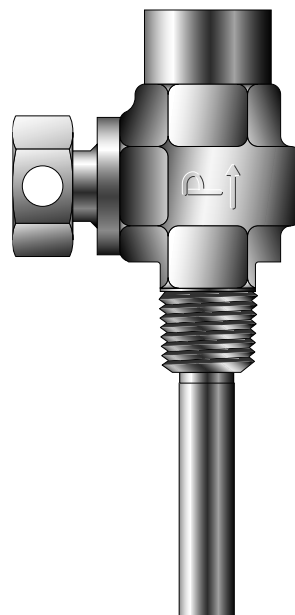

Model Shown:
4M4F-RV6L-SS-2

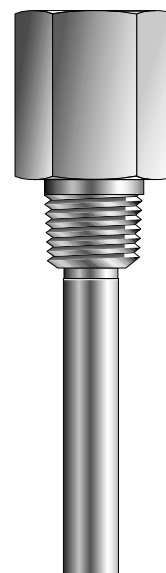

Model Shown:
4M4F-DT6L-SS-2

! WARNING

FAILURE, IMPROPER SELECTION OR IMPROPER USE OF THE PRODUCTS AND/OR SYSTEMS DESCRIBED HEREIN OR RELATED ITEMS CAN CAUSE DEATH, PERSONAL INJURY AND PROPERTY DAMAGE.

This document and other information from Parker Hannifin Corporation, its subsidiaries and authorized distributors provide product and/or system options for further investigation by users having technical expertise. It is important that you analyze all aspects of your application and review the information concerning the product or system in the current product catalog. Due to the variety of operating conditions and applications for these products or systems, the user, through its own analysis and testing, is solely responsible for making the final selection of the products and systems and assuring that all performance, safety and warning requirements of the application are met.

The products described herein, including without limitation, product features, specifications, designs, availability and pricing, are subject to change by Parker Hannifin Corporation and its subsidiaries at any time without notice.

Offer of Sale

The items described in this document are hereby offered for sale by Parker Hannifin Corporation, its subsidiaries or its authorized distributors. This offer and its acceptance are governed by the provisions stated in the "Offer of Sale" located in Catalog 4110 - U Needle Valves (U Series).



Catalog 4160-SC, 20M, 07/02

Parker Hannifin Corporation
Instrumentation Valve Division
2651 Alabama Highway 21 North
Jacksonville, AL 36265-9681
USA
Phone: (256) 435-2130
Fax: (256) 435-7718
www.parker.com/IVD



Parker Hannifin plc
Instrumentation Products Division
Riverside Road
Pottington Business Park
Barnstaple, Devon EX31 1NP
England
Phone: +44 (0) 1271 313131
Fax: +44 (0) 1271 373636
Email: ipd@parker.com
www.parker.com/IPD

