



# **Back Pressure Regulators**

*Instrument / Analyzer Products*

*Catalog 4510/USA  
January 2006*



# ABP1 Series Back Pressure Regulator

Parker Hannifin Corporation's Veriflo Division presents the ABP1 Series back pressure regulator.

The ABP1 is a versatile design for the control of inlet, upstream or back pressure in an instrument or analyzer system. The materials of construction of this regulator make it suitable for applications where corrosive media and or environments are present.



## Features

- ▶ Standard Hastelloy C-22® diaphragm for superior strength and corrosion resistance.
- ▶ Convolute diaphragm provides outlet pressure stability with changes in flow.
- ▶ O<sub>2</sub> cleaned.
- ▶ Integral diaphragm stop provides an additional safety measure.

## Specifications

### Materials of Construction

#### Wetted

Body .....	316L Stainless Steel
Seal Choices .....	PTFE, Fluorocarbon, Kalrez®
Seat O-Ring w/Seal .....	Fluorocarbon, PTFE
Seat & Holder .....	316L Stainless Steel
Diaphragm .....	PTFE-lined Hastelloy C-22®
Diaphragm Assy .....	316L Stainless Steel, PTFE
Outboard Gasket .....	PTFE
Screen .....	316L Stainless Steel

#### Non-wetted

Cap .....	303 Stainless Steel
Cap nut .....	316L Stainless Steel
Knob .....	ABS Plastic (Black) Optional Metal Knob (Black)

### Operating Conditions

Control pressure .....	1-25 psig (2 barg) 2-50 psig (3.5 barg), 3-100 psig (7 barg) 10-250 psig (17 barg), 20-500 psig (35 barg)
Max. temperature of flow media: .....	-15°F to 400°F (-26°C to 204°C)

**Note:** Metal knob option required for higher temperature applications.

### Functional Performance

Design proof pressure .....	750 psig (52 barg)
Design burst pressure .....	1,500 psig (103 barg)
Flow capacity .....	C <sub>v</sub> 0.3 Optional 0.1 C <sub>v</sub> and 0.06 C <sub>v</sub> (SEMI Flow Coefficient Test# F-32-0998)
Maximum Inboard Design	
Leak Rate .....	Bubble Tight

### Internal Volume

5.9cc

### Standard Connections

1/8" or 1/4" female pipe threads (NPTF)

### Approximate Weight

2.3 lbs (1.0 kgm)

Hastelloy C-22® is a registered trademark of Haynes International, Inc. Kalrez® is a registered trademark of DuPont Company.

## Dimensional Data

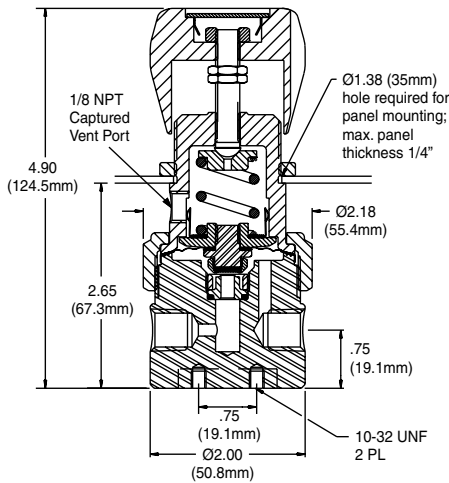

## Flow Curve

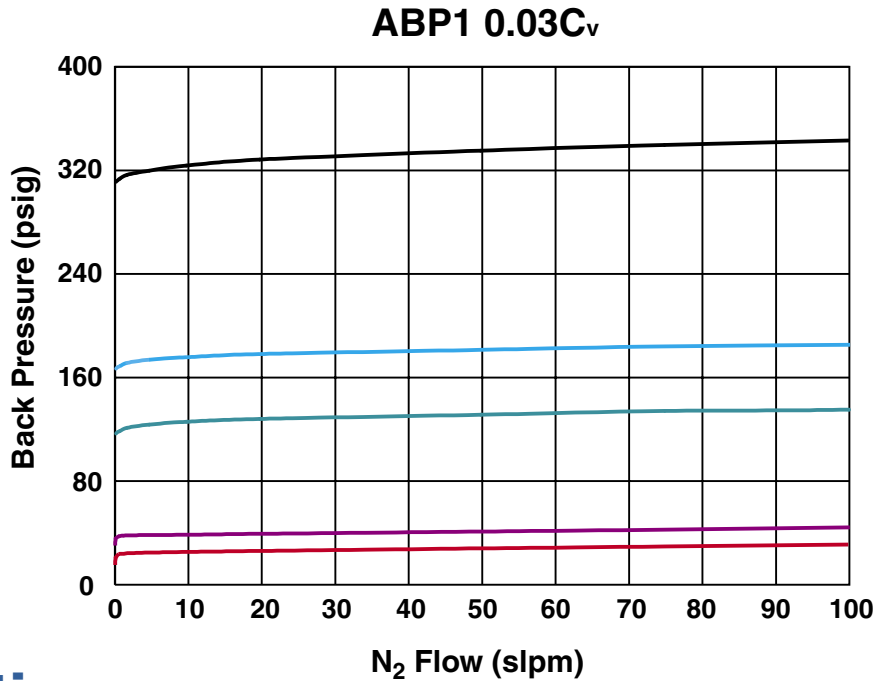

## Porting Configurations

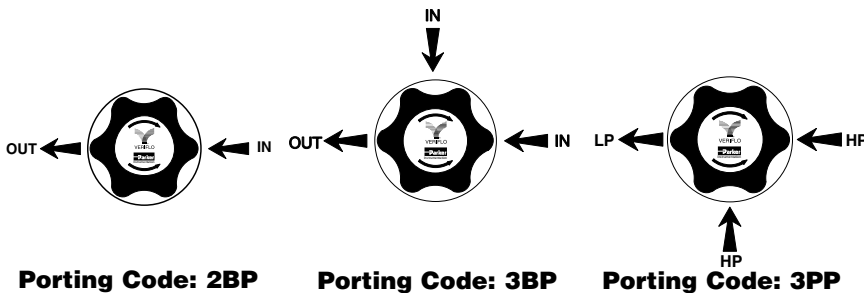

## Ordering Information

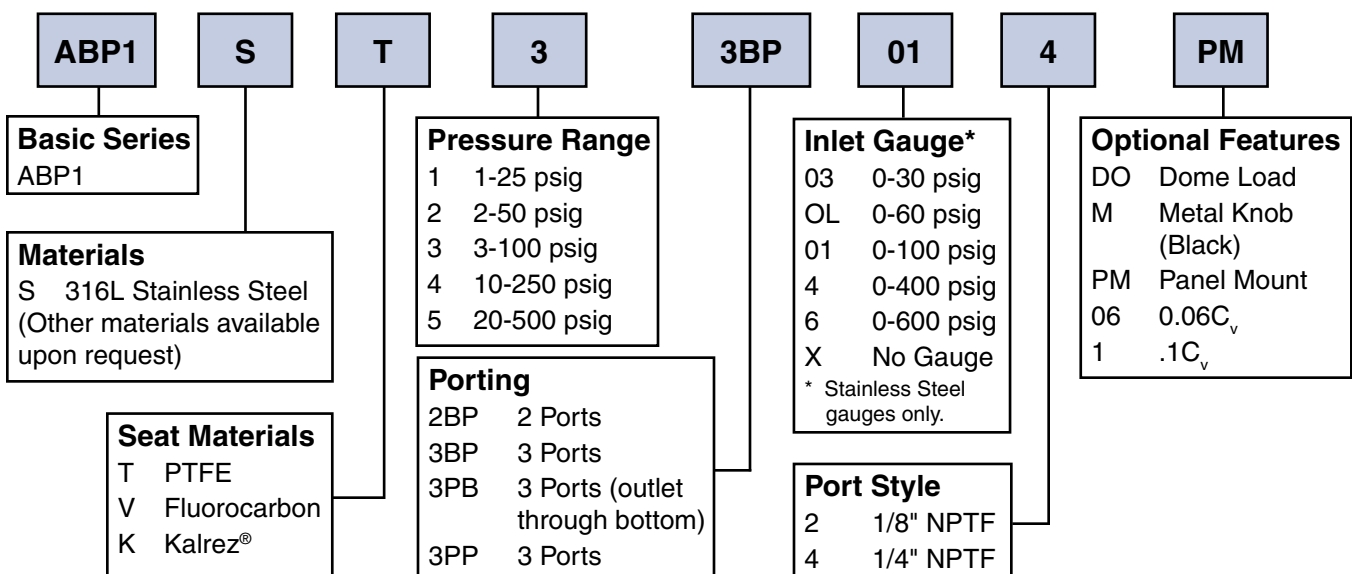

# ABP3 Series Back Pressure Regulator

Parker Hannifin Corporation's Veriflo Division presents the ABP3 Series. This regulator is designed to provide precise inlet, upstream or back pressure control with corrosive media and environments. The large convoluted diaphragm provides the user greater sensitivity of outlet pressures.



## Features

- ▶ Larger diaphragm provides more sensitive pressure adjustments.
- ▶ Standard Hastelloy C-22<sup>®</sup> diaphragm is superior in strength and corrosion resistance, which minimizes the hazards of a rupture.
- ▶ Panel mount standard.
- ▶ Convoluted diaphragm provides outlet pressure stability with changes in flow.
- ▶ O<sub>2</sub> cleaned.
- ▶ Integral stop mechanism limits the travel of the diaphragm and will also provide an additional measure of safety to the user.

## Specifications

### Materials of Construction

#### Wetted

Body .....	316L Stainless Steel,
Seal Choices .....	PTFE, Fluorocarbon, Kalrez <sup>®</sup>
Outboard O-Ring .....	PTFE, Fluorocarbon, Teflon <sup>®</sup>
Diaphragm .....	Hastelloy C-22 <sup>®</sup>
Diaphragm Assy .....	316L Stainless Steel, PTFE
Seat & Holder .....	316L Stainless Steel
Seat O-Ring .....	Fluorocarbon
Screen .....	316L Stainless Steel

#### Non-wetted

Cap .....	Nickel Plated Brass
Cap nut .....	Nickel Plated Brass
Knob .....	ABS Plastic (Black)
	Optional Metal Knob (Black)

### Operating Conditions

Control pressure .....	1-5 psig (.07-.3 barg)
	1-30 psig (.07-2 barg)
	2-60 psig (.2-4 barg)
Max. temperature of flow media .....	-15°F to 400°F
	(-26°C to 204°C)

**Note:** Metal knob option required for higher temperature applications.

### Functional Performance

Design proof pressure .....	90 psig (6 barg)
Design burst pressure .....	180 psig (12.4 barg)
Flow capacity .....	C <sub>v</sub> = 0.3
	Optional .06 C <sub>v</sub> and , 0.1 C <sub>v</sub>
	(SEMI Flow coefficient Test #F-32-0998)

Maximum Inboard Design	
Leak Rate .....	Bubble Tight

### Internal Volume

13.8 cc

### Standard Connections

1/8", or 1/4", female pipe threads (NPT)

### Approximate Weight

4.2 lbs (1.9 kg)

## Dimensional Data

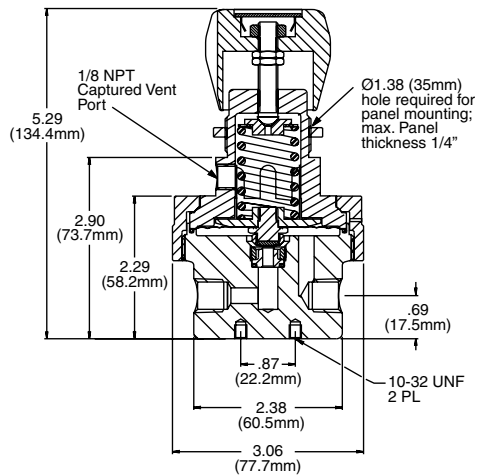

## Flow Curve

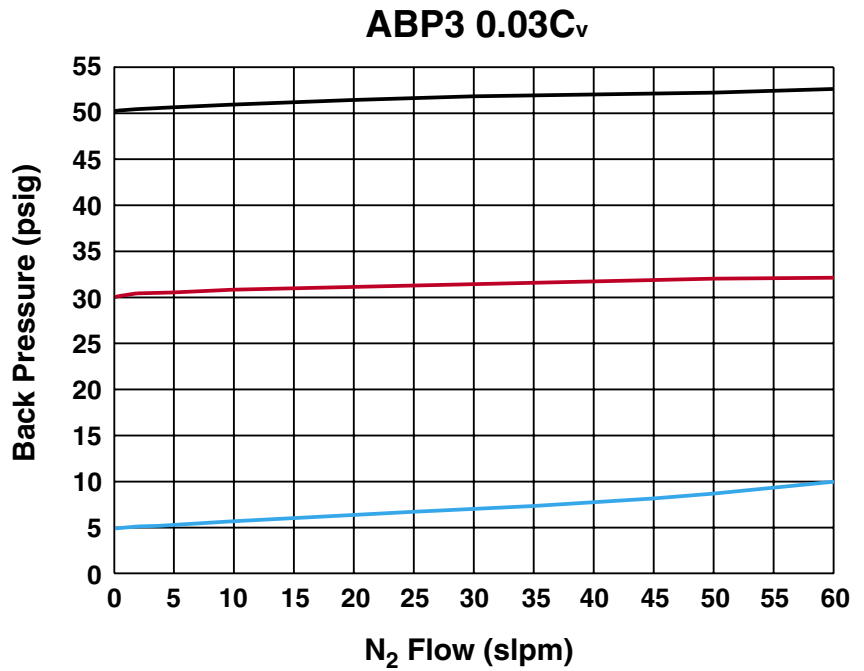

## Porting Configurations

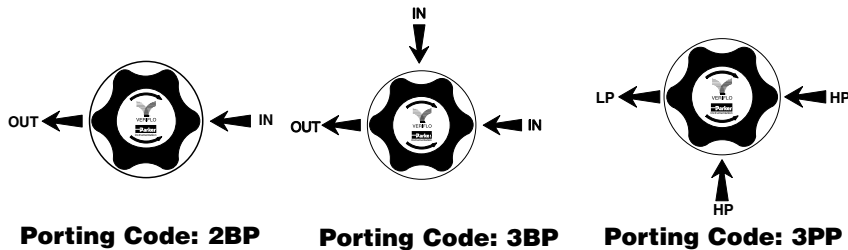

## Ordering Information

<b>ABP3</b>	<b>S</b>	<b>T</b>	<b>2</b>	<b>3BP</b>	<b>03</b>	<b>4</b>	<b>06</b>
<b>Basic Series</b> ABP3	<b>Materials</b> S 316L Stainless Steel (Other materials available upon request.)		<b>Pressure Range</b> 1 1-5 psig 2 1-30 psig 3 2-60 psig	<b>Porting</b> 2BP 2 Ports 3BP 3 Ports 3PP 3 Ports	<b>Inlet Gauge*</b> 05 0-15 psig 03 0-30 psig OL 0-60 psig 01 0-100 psig X No Gauge <small>* Stainless Steel gauges only.</small>	<b>Optional Features</b> DO Dome Load 06 0.06C <sub>v</sub> 1 .1C <sub>v</sub> M Metal Knob (Black)	
<b>Seat Materials</b> K Kalrez® T PTFE V Fluorocarbon					<b>Port Style</b> 2 1/8" NPTF 4 1/4" NPTF	<b>Note:</b> All units are standard with threaded caps (bonnets) and nuts for panel mounting.	



# BPR50 Series Back Pressure Regulator

Parker Hannifin Corporation's Veriflo Division presents the BPR50. The BPR50 is a piston style back pressure regulator designed to control upstream or back pressures. The BPR50 can be used with high pressure corrosive and non-corrosive liquids and gases at pressures up to 2,000 psig.



**Note:** Optional "T" Bar Handle shown

## Features

- ▶ 316L Stainless Steel construction
- ▶ Gas or Liquid Service
- ▶ Flow coefficient of 0.45  $C_v$
- ▶ Simple construction makes maintenance easy
- ▶ Adjustable pressures from 100 to 1,200 psig and 200 to 2000 psig
- ▶ Panel mountable
- ▶ O<sub>2</sub> cleaned

## Specifications

### Materials of Construction

#### Wetted

Body .....	316L Stainless Steel
Seal .....	Glass filled PTFE, optional PCTFE
Seal Holder .....	316L Stainless Steel
O-ring .....	Fluorocarbon, optional Kalrez®
Piston .....	316L Stainless Steel
Gasket .....	PTFE
Spring .....	Stainless Steel

#### Non-wetted

Cap .....	Nickel plated Brass
Broach Stem .....	316L Stainless Steel
T Bar Handle .....	Nickel Plated Brass

### Operating Conditions

Control pressure .....	100-1,200 psig (7 - 83 barg)
	200-2,000 psig (14 - 138 barg)
Max. temperature of flow media .....	-15°F to 400°F
	(-26°C to 204°C)

### Functional Performance

Design Burst pressure .....	6,000 psig (414 barg)
Design Proof pressure .....	3,000 psig (276 barg)
Flow capacity .....	$C_v = .45$
	(SEMI Flow Coefficient Test #F-32-0998)
Maximum Inboard Design	
Leak Rate .....	Bubble Tight
Maximum Liquid Flow .....	20 lpm (5 gpm)
Hysteresis .....	20 psig (1.4 barg)
Sensitivity .....	0.5 psig (.03 barg)

### Internal Volume

5 cc

### Approximate Weight

2.2 lbs. (1.0 kg)

## Dimensional Data

BPR50 with Optional T Bar Handle Actuation Device

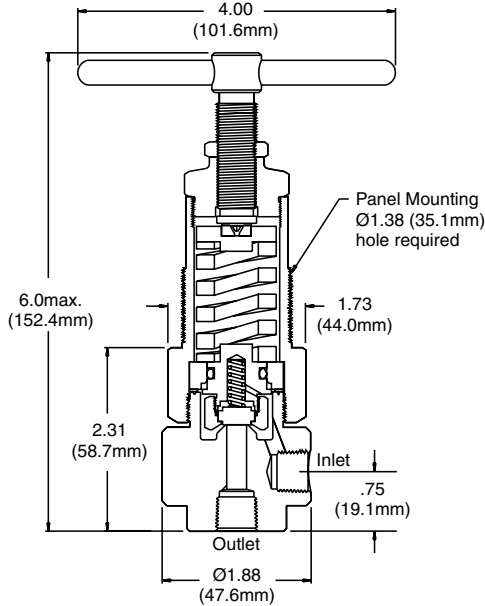

BPR50 with Standard Broach Stem Actuation Device

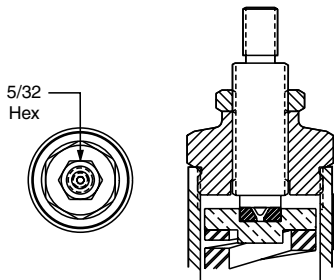

## Flow Curve

Range: 100-1200 psig  
200-2000 psig

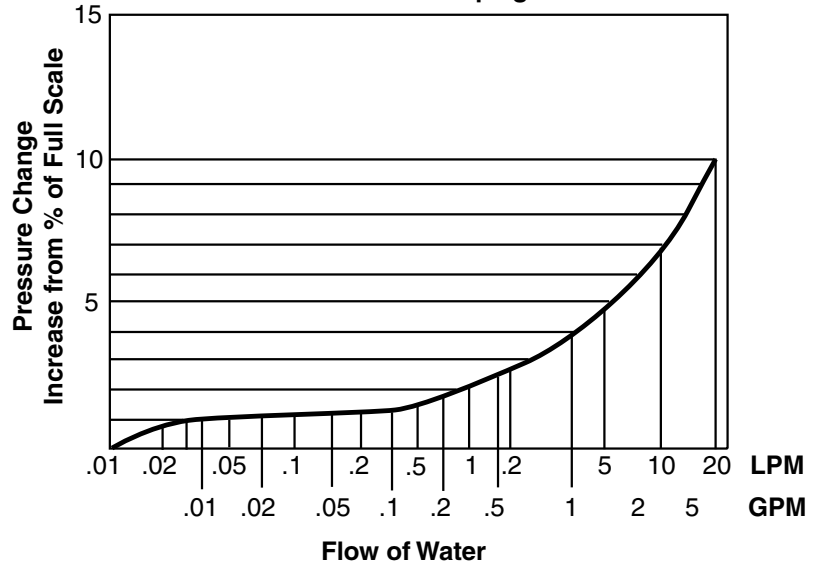

## Porting Configurations

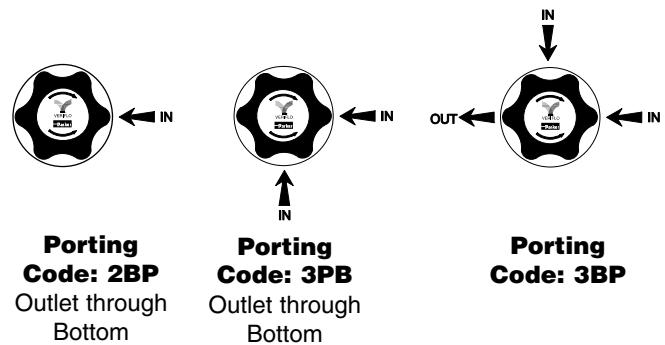

## Ordering Information

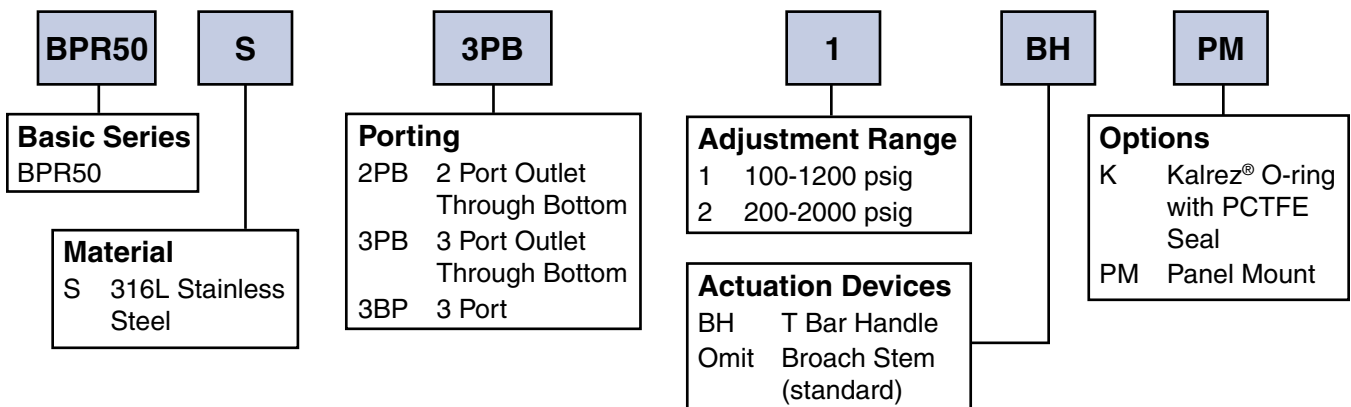



**Parker Hannifin Corporation**  
Veriflo Division  
250 Canal Boulevard  
Richmond, CA 94804-0034  
Telephone: 510.235.9590  
Fax: 510.232.7396  
[www.veriflo.com](http://www.veriflo.com)

Catalog 4510, 01/06