



Ball Valves (HB Series)

*Catalog 4121-HB
Revised, April 2005*



Introduction

Parker High Pressure HB4 Series Ball Valves provide reliable shut-off or switching functions. The upper and lower trunnion bearings enhance the resistance of the trunnions against seizure, and increase the valve life in extreme applications. The compact and rugged design employs spring-loaded seats for high cycle life and low operating torques at pressures up to 10,000 psig (689 bar).

Features

- PEEK trunnion bearings for longer cycle life
- Two-way and three-way designs
- Compact FNPT version for tight work areas
- Blow-out resistant two-piece ball/stem
- Full operating pressure at any port
- Low operating torque
- Manual, electric or pneumatic actuation
- Panel mountable to 3/8" (9.6 mm) thickness
- No packing to adjust
- Color coded fracture resistant handles
- Handle indicates direction of flow
- Positive handle stops
- Wide variety of US customary and SI ports
- Top of stem marked to indicate flow direction
- 100% factory tested
- Compact package
- Heat code traceability

Specifications

- **Pressure rating:** 10,000 psig (689 bar) CWP with PEEK (PKR) Seats; 6,000 psig (414 bar) CWP with PCTFE (K) Seats
- **Temperature rating:** -65°F to 400°F (-54°C to 204°C)
- **Body material:** Stainless steel
- **Body configurations:** Two-way and three-way
- **Port connections:** Tube compression (CPI™ / A-LOK®); short and long female NPT
- **Port size:** 1/8" – 1/2" (6 mm to 12 mm)

Flow Data

- Two-way HB4L: $C_v = 1.02$; $x_T = 0.42$;
orifice = 0.188" (4.8 mm)
- Three-way HB4X: $C_v = 0.62$; $x_T = 0.71$;
orifice = 0.188" (4.8 mm)

Tested in accordance with ISA S75.02. Gas flow will be choked when $P_1 - P_2 / P_1 = x_T$.

Testing

Standard production testing – valves are 100% factory tested with nitrogen at 1,000 psig (69 bar) for leakage at the seats and body seals. Both areas are required to have less than 0.1 SCCM leakage. Optional testing is available upon request. Consult your authorized Parker Instrumentation Distributor or the factory for further information.



Two-way HB4L design



Three-way HB4X design

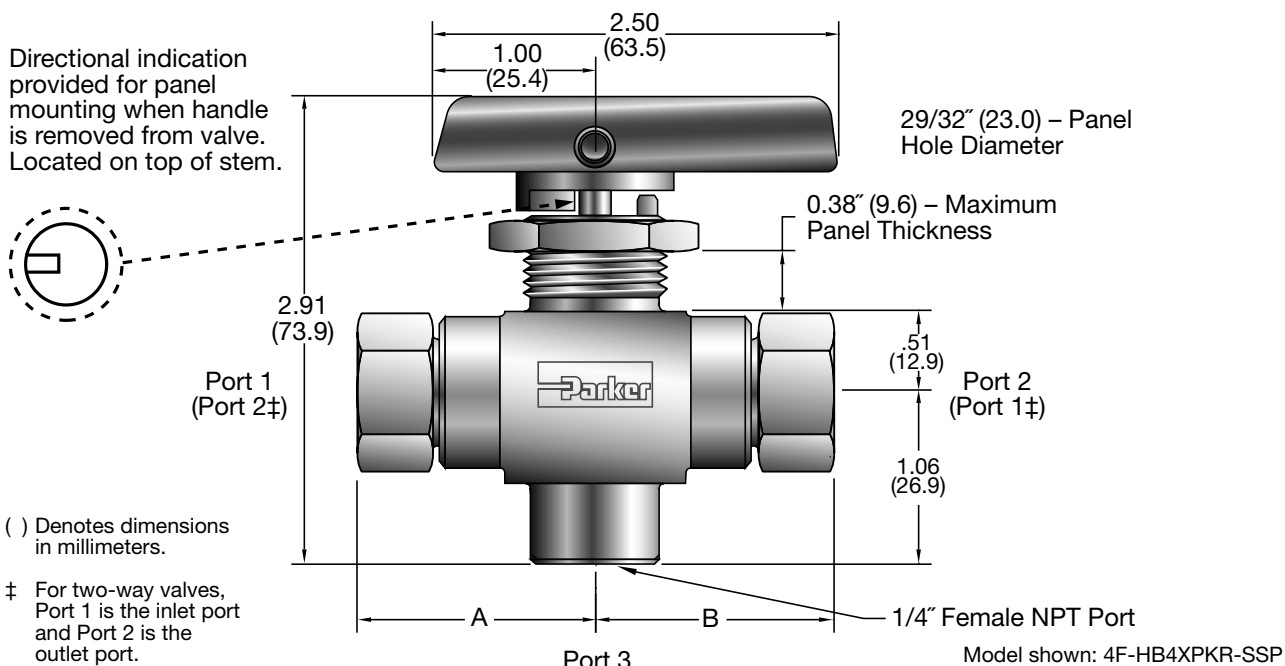

Dimensions / Pressure Data

Basic Part Number*	Pressure Rating @100°F (38°C)		End Connection Port 1 / Port 2	Dimensions			
	psig	bar		A††		B††	
				inch	mm	inch	mm
2F-HB4	10,000	689	1/8" Female NPT	1.47	37.3	1.47	37.3
4F-HB4**	10,000	689	1/4" Female NPT	1.47	37.3	1.47	37.3
4FL-HB4	10,000	689	1/4" Female NPT	1.97	50.0	1.97	50.0
4A-HB4	10,000	689	1/4" A-LOK® Compression	2.07	52.6	2.07	52.6
4Z-HB4	10,000	689	1/4" CPI™ Compression	2.07	52.6	2.07	52.6
M6A-HB4	10,000	689	6 mm A-LOK® Compression	2.07	52.6	2.07	52.6
M6Z-HB4	10,000	689	6 mm CPI™ Compression	2.07	52.6	2.07	52.6
6A-HB4	6,600†	455	3/8" A-LOK® Compression	2.19	55.6	2.19	55.6
6Z-HB4	6,600†	455	3/8" CPI™ Compression	2.19	55.6	2.19	55.6
8A-HB4	6,300†	434	1/2" A-LOK® Compression	2.30	58.4	2.30	58.4
8Z-HB4	6,300†	434	1/2" CPI™ Compression	2.30	58.4	2.30	58.4
M8A-HB4	7,975†	550	8 mm A-LOK® Compression	2.07	52.6	2.07	52.6
M8Z-HB4	7,975†	550	8 mm CPI™ Compression	2.07	52.6	2.07	52.6
M10A-HB4	6,525†	450	10 mm A-LOK® Compression	2.19	55.6	2.19	55.6
M10Z-HB4	6,525†	450	10 mm CPI™ Compression	2.19	55.6	2.19	55.6
M12A-HB4	6,162†	425	12 mm A-LOK® Compression	2.30	58.4	2.30	58.4
M12Z-HB4	6,162†	425	12 mm CPI™ Compression	2.30	58.4	2.30	58.4

* Flow configurations are two-way (HB4L) and three-way (HB4X); Seat materials are PEEK (Polyetheretherketone) and PCTFE (Polychlorotrifluoroethylene).

** Designed with shorter end-to-end dimensions than the 4FL model to save space.

† Reduced pressure rating is determined by the maximum rated pressure of the tubing as stated in the Parker Instrument Tubing Selection Guide Bulletin 4200-TS. The working pressure ratings are limited by the seat material (PCTFE – 6,000 psig (414 bar) maximum and PEEK – 10,000 psig (689 bar) maximum) and the temperature of the application.

†† For CPI™ and A-LOK®, dimensions are measured with nuts in the finger tight position.

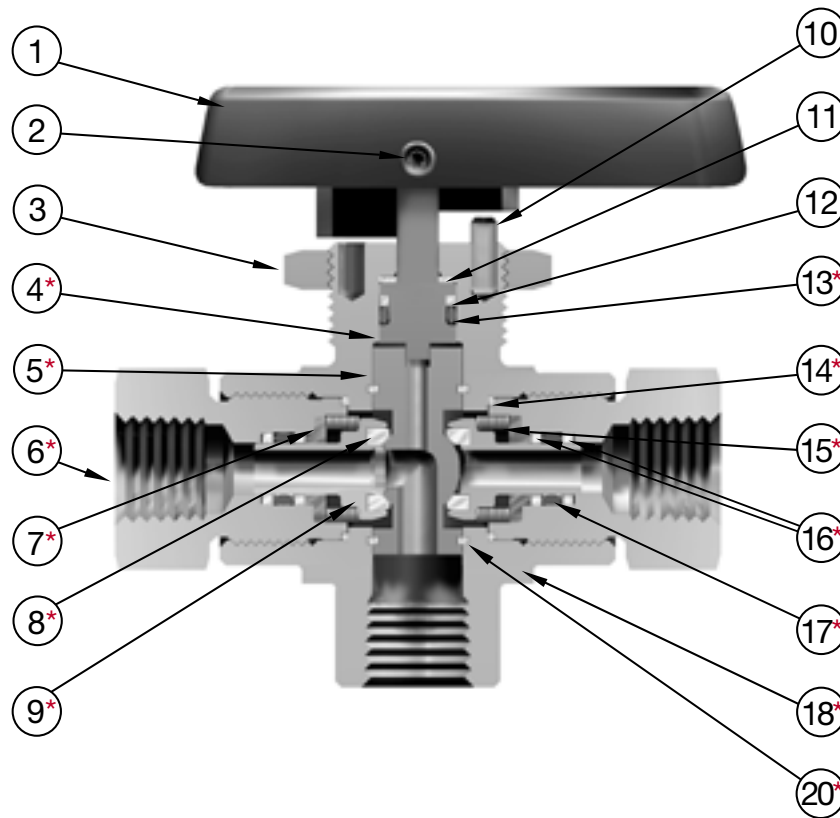

Materials of Construction

No.	Part Description	6,000 psi (414 bar)	10,000 psi (689 bar)
1	Handle/insert	Nylon 6/6/316 SS	Nylon 6/6/316 SS
2	Handle screw	Stainless steel	Stainless steel
3	Panel nut	316 Stainless steel	316 Stainless steel
4*	Stem	ASTM A 479 Type 316	ASTM A 479 Type 316
5*	Ball trunnion	ASTM A 479 Type 316	ASTM A 479 Type 316
6*	Port end connector	ASTM A 479 Type 316	ASTM A 479 Type 316
7*	Spring washer	ASTM A 479 Type 316	ASTM A 479 Type 316
8*	Seat	PCTFE	PEEK
9*	Seat retainer	ASTM A 276 Type 316	ASTM A 276 Type 316
10	Handle stop pins	302 Stainless steel	302 Stainless steel
11	Stem washer	PEEK	PEEK
12	Stem o-ring back-up	PTFE	PTFE
13*	Stem o-ring	Fluorocarbon rubber**	Fluorocarbon rubber**
14*	Connector end seal	PEEK	PEEK
15*	Spring	ASTM A 313 Type 631	ASTM A 313 Type 631
16*	Seat retainer o-ring back-up	PTFE	PTFE
17*	Seat retainer o-ring	Fluorocarbon rubber**	Fluorocarbon rubber**
18*	Valve body	ASTM A 276 Type 316	ASTM A 276 Type 316
19*	Pipe plug (Not shown/HB4L only)	316 Stainless steel	316 Stainless steel
20*	Trunnion bearing	PEEK	PEEK

* Wetted parts

** Optional elastomer seals available

Lubrication: Perfluorinated polyether

Pressure vs. Temperature

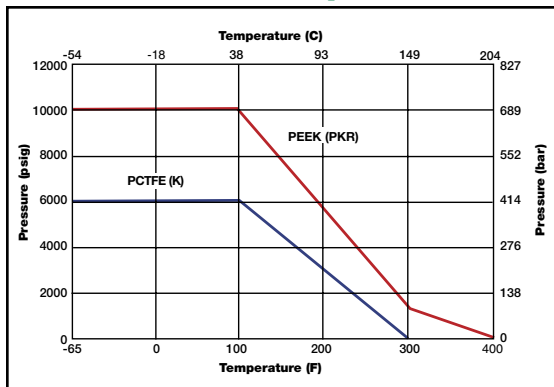

Note: To determine MPa, multiply bar by 0.1

This pressure versus temperature chart reflects the maximum temperature range of indicated materials.

When combining seat and seal materials, the most restrictive temperature rating of the seats or seals becomes the limiting factor on valve temperature range.

Temperature Ratings:

- Buna-N (Nitrile) Rubber: -40°F to 250°F (-40°C to 121°C)
- Ethylene Propylene Rubber: -65°F to 300°F (-54°C to 149°C)
- Fluorocarbon Rubber: -15°F to 400°F (-26°C to 204°C)

Flow Calculations (Two-way HB4L)

Inlet Pressure		Pressure Drop P		Water @ 60°F (16°C)		Air @ 60°F (16°C)	
psig	bar	psig	bar	gpm	m ³ /hr	scfm	m ³ /hr
100	7	1	0.1	1.0	0.2	10.8	17.4
		10	0.7	3.2	0.7	32.0	50.7
		50	3.5	7.2	1.6	50.5	76.0
1000	69	10	0.7	3.2	0.7	101.3	171.3
		100	6.9	10.2	2.3	297.7	502.3
		500	34.5	22.8	5.2	446.7	749.6
3000	207	100	6.9	10.2	2.3	542.0	919.9
		1000	69.0	32.3	7.3	1297.0	2198.9
		1500	103.4	39.5	9.0	1327.2	2248.8
6000	414	1000	69.0	32.3	7.3	2158.5	3662.7
		2000	137.9	45.6	10.4	2188.5	4388.6
		3000	206.8	55.9	12.7	2647.9	4486.8
10000	689	1000	69.0	32.3	7.3	2954.3	5020.2
		2000	137.9	45.6	10.4	3818.4	6487.0
		3000	206.8	55.9	12.7	4236.2	7194.9

Flow Calculations (Three-way HB4X)

Inlet Pressure		Pressure Drop P		Water @ 60°F (16°C)		Air @ 60°F (16°C)	
psig	bar	psig	bar	gpm	m ³ /hr	scfm	m ³ /hr
100	7	1	0.1	0.6	0.1	6.6	10.6
		10	0.7	2.0	0.4	20.0	31.9
		50	3.5	4.4	1.0	37.1	57.4
1000	69	10	0.7	2.0	0.4	61.8	104.4
		100	6.9	6.2	1.4	187.2	316.1
		500	34.5	13.9	3.1	337.4	567.7
3000	207	100	6.9	6.2	1.4	333.1	565.4
		1000	69.0	19.6	4.5	903.4	1532.8
		1500	103.4	24.0	5.5	1004.4	1703.2
6000	414	1000	69.0	19.6	4.5	1393.5	2365.2
		2000	137.9	27.7	6.3	1803.8	3060.4
		3000	206.8	34.0	7.7	2004.9	3399.8
10000	689	1000	69.0	19.6	4.5	1858.9	3159.0
		2000	137.9	27.7	6.3	2499.6	4247.2
		3000	206.8	34.0	7.7	2903.0	4932.1

How to Order

The correct part number is easily derived by following the circled number sequence. The six product characteristics required are coded as shown. *Note: If ports 1 and 2 are the same, eliminate the port 2 designator.

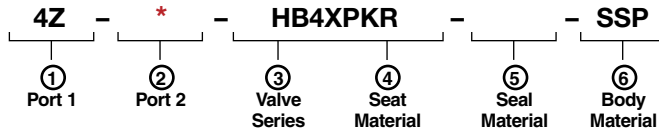

Describes a HB4X, three-way ball valve with 1/4" CPI™ compression end connections for ports 1 and 2, PEEK seats and fluorocarbon rubber seals, stainless steel body construction, and a panel mounting nut. Port 3 is always a 1/4" FNPT port.

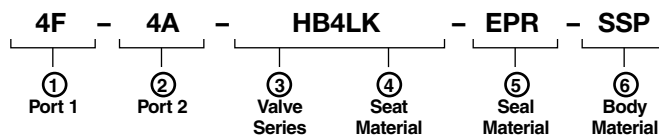

Describes a HB4L, two-way ball valve with a 1/4" female NPT port 1 and a 1/4" A-LOK® compression port 2, PCTFE seats and ethylene propylene rubber seals, stainless steel body construction, and a panel mounting nut.

Note: Port 3 will always have a 1/4" MNPT plug when ordering a HB4L Series two-way ball valve.

① Port 1	② Port 2	③ Valve Series	④ Seat Material	⑤ Seal Material	⑥ Body Material
2F 1/8" Female NPT	2F 1/8" Female NPT	HB4L (2-way)	PKR (PEEK-Polyetheretherketone)	Blank- (Fluorocarbon Rubber)	SSP (Stainless Steel with Panel Nut)
4F 1/4" Female NPT	4F 1/4" Female NPT				
4FL 1/4" Female NPT (Long)	4FL 1/4" Female NPT (Long)				
4A 1/4" A-LOK® Compression	4A 1/4" A-LOK® Compression				
4Z 1/4" CPI™ Compression	4Z 1/4" CPI™ Compression				
6A 3/8" A-LOK® Compression	6A 3/8" A-LOK® Compression				
6Z 3/8" CPI™ Compression	6Z 3/8" CPI™ Compression				
8A 1/2" A-LOK® Compression	8A 1/2" A-LOK® Compression				
8Z 1/2" CPI™ Compression	8Z 1/2" CPI™ Compression				
M6A 6 mm A-LOK® Compression	M6A 6 mm A-LOK® Compression				
M6Z 6 mm CPI™ Compression	M6Z 6 mm CPI™ Compression				
M8A 8 mm A-LOK® Compression	M8A 8 mm A-LOK® Compression				
M8Z 8 mm CPI™ Compression	M8Z 8 mm CPI™ Compression				
M10A 10 mm A-LOK® Compression	M10A 10 mm A-LOK® Compression				
M10Z 10 mm CPI™ Compression	M10Z 10 mm CPI™ Compression				
M12A 12 mm A-LOK® Compression	M12A 12 mm A-LOK® Compression				
M12Z 12 mm CPI™ Compression	M12Z 12 mm CPI™ Compression				

Available End Connections

Z – One ferrule CPI™ compression port



A – Two ferrule A-LOK® compression port



F – ANSI/ASME B1.20.1 internal pipe threads



Actuator Options

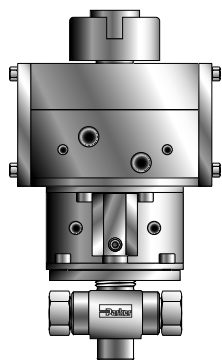

**Double Acting (61AD)
Pneumatic Actuator**

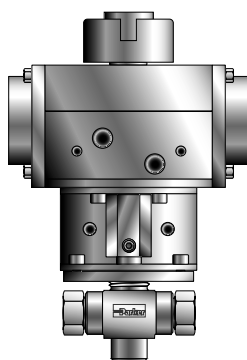

**Spring Return (61AC & AO)
Pneumatic Actuator**

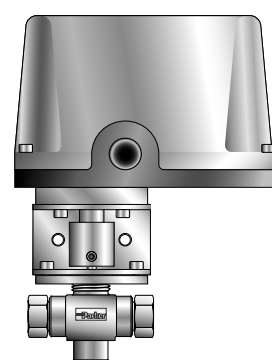

**70 and 80 Series
Electric Actuator**

How to Order Options

Lock-Out Devices – Add the suffix **-LD** to the end of the part number to order directly on the valve.
(Example: 2F-HB4LPKR-BN-SSP-**LD**).
For field installation, simply substitute the correct valve series number after LD. (Example: **LD**-HB4L).

Colored Handles – Add the designator corresponding to the correct handle as a suffix to the part number:

W - white B - blue
G - green R - red
Y - yellow

(Example: M6A-HB4XPKR-SSP-**G**).

Oxygen Cleaning – Add the suffix **-C3** to the end of the part number to receive valves cleaned and assembled for oxygen service in accordance with Parker Specification ES8003. (Example: 4A-HB4LPKR-EPR-SSP-**C3**).

Pneumatic Actuators – For detailed actuator information, refer to Catalog 4123-PA. For factory assembly, add the actuator part number as the suffix to the valve part number. (Example: 4FL-HB4XK-SSP-**61ACX-2**).

For field installation, specify the actuator desired (Example: 61ACX-2). The appropriate mounting hardware may be obtained by adding the valve series and actuator size to the prefix **MK-**.
(Example: **MK**-HB4X-61).

Electric Actuators – For detailed actuator information, refer to Catalog 4123-EA. For factory assembly, add the actuator part number as the suffix to the valve part number (Example: 6A-HB4XPKR-SSP-**71XA**).
For field installation, specify the actuator desired (Example: 71XA). The appropriate mounting hardware may be obtained by adding the valve series and actuator series to the prefix **MK-** (Example: **MK**-HB4X-70).

How to Order Maintenance Kits

Handle Kits: HB4-Handle-Color (Example: HB4-HANDLE-RED). Consists of a red handle and handle screw.

Two-way Seal Kits: KIT-HB4LPKR or KIT-HB4LK – Consists of a two-way trunnion, springs, stem washers, stem seal, back-up ring, end connector seals, seat springs, seat retainer seals, seat retainer back-up rings, and seat assemblies.

Three-way Seal Kits: KIT-HB4XPKR or KIT-HB4XK – Consists of a three-way trunnion, springs, stem washers and stem seal, back-up ring, end connector seals, seat springs, seat retainer seals, seat retainer back-up rings, and seat assemblies.



WARNING

FAILURE, IMPROPER SELECTION OR IMPROPER USE OF THE PRODUCTS AND/OR SYSTEMS DESCRIBED HEREIN OR RELATED ITEMS CAN CAUSE DEATH, PERSONAL INJURY AND PROPERTY DAMAGE.

This document and other information from Parker Hannifin Corporation, its subsidiaries and authorized distributors provide product and/or system options for further investigation by users having technical expertise. It is important that you analyze all aspects of your application and review the information concerning the product or system in the current product catalog. Due to the variety of operating conditions and applications for these products or systems, the user, through its own analysis and testing, is solely responsible for making the final selection of the products and systems and assuring that all performance, safety and warning requirements of the application are met.

The products described herein, including without limitation, product features, specifications, designs, availability and pricing, are subject to change by Parker Hannifin Corporation and its subsidiaries at any time without notice.

Offer of Sale

The items described in this document are hereby offered for sale by Parker Hannifin Corporation, its subsidiaries or its authorized distributors. This offer and its acceptance are governed by the provisions stated in the "Offer of Sale" located in Catalog 4110-U Needle Valves (U Series).



Parker Hannifin Corporation

Instrumentation Products Division
2651 Alabama Highway 21 North
Jacksonville, AL 36265-9681 USA
Phone: (256) 435-2130
Fax: (256) 435-7718
www.parker.com/ipdus

Parker Hannifin plc

Instrumentation Products Division
Riverside Road
Pottington Business Park
Barnstaple, Devon EX31 1NP
England
Phone: +44 (0) 1271 313131
Fax: +44 (0) 1271 373636
E-mail: ipd@parker.com
www.parker.com/ipd